

How to Make Extra Money **FIXING RADIOS**

NATIONAL RADIO INSTITUTE, WASHINGTON, D. C.

No. 23 How To Fix a Receiver That
Squeals and Motorboats

RADIO SERVICING METHODS



NRI TRAINING

Pay!...

Dear Mr. Smith:

Before I enrolled with you I thought radio was a subject that required a college education to understand. But I did enroll, even though I thought it was a gamble. Soon I discovered that with your method of teaching not only did I begin to know radio, but I was making side money. I am now operating a full time radio business. My future and that of my family is assured, thanks to NRI.

P.J.P., New Jersey



COPYRIGHT 1947 BY

**NATIONAL RADIO INSTITUTE
WASHINGTON, D. C.**

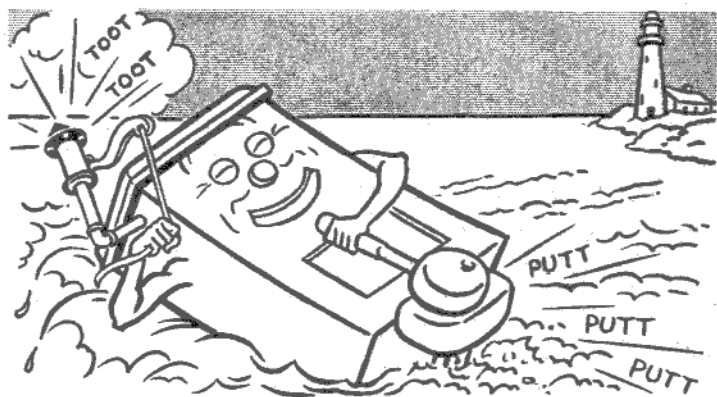

How To Fix a Receiver That Squeals and Motorboats

OSCILLATION is the technical name for the defect that causes a receiver to produce squealing or whistling sounds along with the desired program. Although it is not as common a complaint of modern receivers as it was of older sets, you will still meet it at least once in a while in your service work.

The customer whose set oscillates may say that it is noisy or hums. However, you will find it easy to distinguish oscillation from these other defects when you confirm the complaint. The characteristic whistle or squeal of oscillation is *not* at all like the popping, crackling, frying sounds we call noise, and is too high pitched to be classed as a hum. Most of the whistles will be rather high in frequency, although they may vary in both pitch and intensity as the receiver is tuned. Whenever low-frequency oscillation occurs, it produces a "putt-putt-putt" sound that is similar to the exhaust sound of a motorboat—in fact, low-frequency oscillation is popularly called "motorboating."

Before you can say definitely that a set is oscillating, you must be sure that the whistle is actually caused by a receiver defect and is not the result of some external condition. We will describe several of these external conditions briefly in this RSM Booklet and will give you

more complete descriptions of them elsewhere in your Course. The most important thing to remember is the fact that external causes generally produce whistles on only a few stations (sometimes only on one), whereas a receiver defect causes interference with many station signals. When the oscillation is severe, you may hear nothing but the whistle or motorboating sound.

► You must not confuse the receiver defect "oscillation" with the action of the *local oscillator* in a superheterodyne. The local oscillator tube, of course, is supposed to oscillate; oscillation is a defect only when it occurs in an amplifier or a detector stage.

Before we describe the tests used to localize oscillation, let's first see just what causes it; then we will know what we are looking for when we have this complaint.

CONDITIONS FOR OSCILLATION

Before oscillation can occur, three conditions must exist in the set:

1. A *feedback path* must exist that will allow energy to get out of some circuit and get back into another one in an undesired manner.

2. The feedback energy must have the *proper phase relationship* so that, at the point where it gets back into the signal path, it will aid the signals coming through that circuit, rather than oppose them.

3. The feedback energy must be *sufficiently large* to overcome the losses in the circuit into which it is fed.

As a matter of fact, it is impractical and too costly to try to eliminate ALL feedback. The receiver designer merely keeps it small enough to allow the set to be stable and reliable in its operation. Therefore, whenever oscillation occurs, something has happened that provides *another or a better feedback path* (one that was not present originally or was suppressed), or the *phase* of the feedback is shifted, or the *amount* of feedback is increased.

Feedback is a very descriptive term. It means just what it says—energy is "fed back" from one circuit in the receiver to another circuit nearer the antenna. In other words, signals travel in the wrong direction

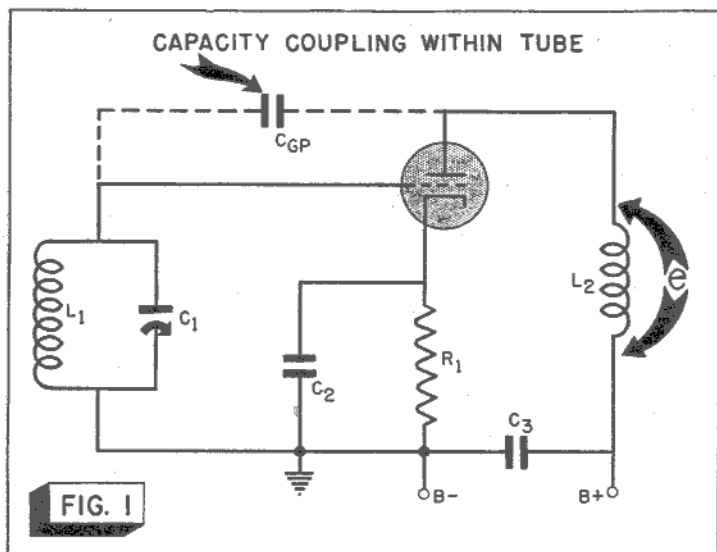

through the receiver over feedback paths. This reversal of the normal direction of signal movement can occur only when there is an undesired coupling between circuits in the same stage or in different stages. This coupling may be inductive coupling, or may be stray capacity between circuit wires or within tubes.

► Fig. 1 shows an example of capacitive coupling. When a signal is passing through this stage, there will be a signal voltage e across the plate load coil L_2 . If there is any capacity coupling between the plate and the grid circuits, as shown by the dotted lines and condenser C_{GP} , then the voltage e will be applied, through C_{GP} and C_3 , across the tuned circuit. This is shown in Fig. 2. Since the voltage e is the amplified signal voltage across the load, it is always considerably greater than the input signal. The amount of this voltage that appears across the resonant circuit L_1 - C_1 depends on the Q of the resonant circuit and on the reactance of the capacity C_{GP} .

► If the capacity C_{GP} is small, there will not be enough voltage fed back to cause trouble. Therefore, every effort is made to keep this stray capacity down to a low level. Today, the triode tube is rarely used as an r.f. amplifier; instead, as shown in Fig. 3, pentode tubes are used al-

most exclusively as r.f. amplifiers in broadcast-band receivers because the screen grid acts as a shield between the grid and the plate within the tube, and reduces the capacity between these two elements. However, there is still stray capacity between the grid and the plate circuits outside the tube, so the grid and the plate leads are kept as short as possible and are well separated to minimize this capacity.

Energy can get back just as well if the magnetic field of the plate load coil (L_2) happens to link with the grid coil (L_1). Therefore, as Fig. 3 shows, these coils are shielded from each other, or are kept separated, and are so placed that their fields have as little inter-action as possible.

Even the tube is shielded to minimize stray coupling between the grid and plate circuits. (Incidentally, schematic diagrams may not indicate tube and coil shields, but these shields are normally used, whether shown or not.)

DEFECTS CAUSING OSCILLATION

Because of the design precautions we have just described, the single stage circuit shown in Fig. 3 is not likely to oscillate unless certain defects occur. For example, when a pentode tube is used, the screen grid will be an effective shield as long as the screen by-pass con-

FIG. 2. This circuit shows why feedback occurs when grid-to-plate capacity exists in the amplifier shown in Fig. 1. The amplified signal voltage, e , developed across the plate load in Fig. 1 is here represented by the symbol for an a.c. generator. As you can see, the grid-to-plate capacity C_{GP} completes a circuit from this voltage source to the tuned circuit. Therefore, part of the voltage e will appear across the tuned circuit—in other words, part of the output voltage of the amplifier will be fed back to the amplifier input.

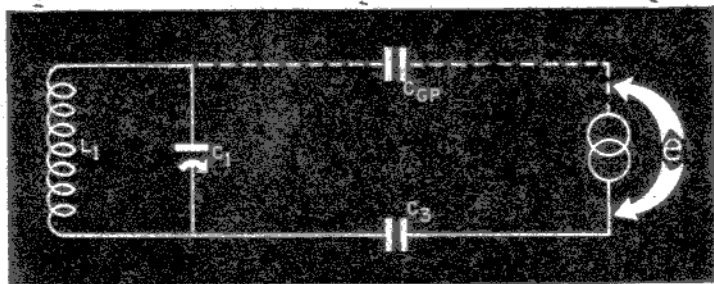

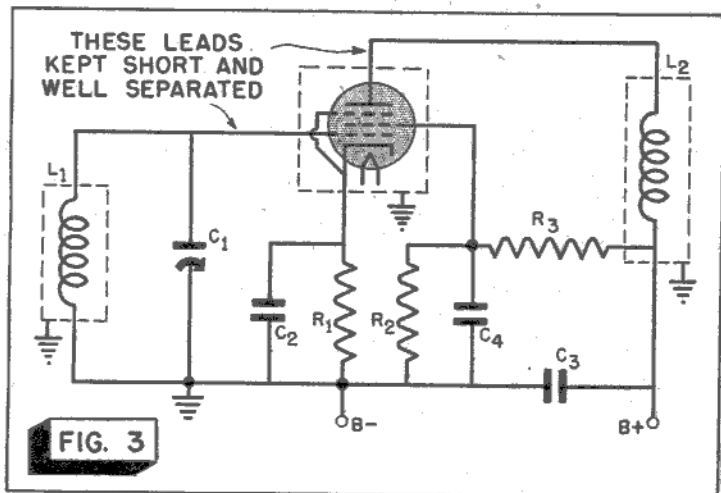

denser C_4 is in good condition. If this by-pass condenser opens, however, energy fed back from the plate to the grid may set up enough signal in the input circuit to control the plate current and cause the stage to become an oscillator. In addition, if the shield is left off the tube, stray coupling between the grid and the plate circuits may cause oscillation. Improper voltages may be responsible, too—excessive screen grid voltage (because of an open bleeder resistor R_2) or a lack of bias (caused by a shorted C_2) may cause the stage to be unstable. Finally, an amplifying tube with a higher-than-normal g_m may cause trouble because it develops a higher-than-normal load signal voltage. These last two possibilities—improper voltages or a high g_m tube—can cause oscillation only if some feedback path to the input circuit exists that permits a fraction of the output voltage to be applied to the input. Since these defects tend to raise the output voltage, their effect is to increase the amount of energy fed back to the input. Of course, if there is no feedback path, or only a very poor one, then even a large increase in output voltage will not cause oscillation.

Therefore, in a single stage, if the circuit wiring has not been disturbed so as to provide a better-than-normal feedback path, there are four possible causes of oscillation: 1, an open screen grid by-pass condenser; 2, lack

of shielding; 3, improper voltages; 4, a high g_m tube. The last is not common.

By-Pass Condenser Troubles. While we are discussing conditions that may cause oscillation, it is well to learn about some conditions that will *not cause* oscillation. We can make use of this knowledge in the effect-to-cause reasoning process, because it will enable us to rule out at once defects that cannot cause the complaint.

For example, in Fig. 3, regeneration cannot be caused by an open in condenser C_2 . In this case, a portion of the plate signal voltage will be developed across resistor R_1 by the plate current. But, although this signal voltage will then be in the grid circuit, it will be out of phase with the grid signal voltage. To see why this is so, consider what happens in the circuit. When the grid signal swings in the positive direction, the plate current increases. The increased plate current in turn increases the voltage across R_1 , thus driving the grid in the negative direction (opposite to the signal swing). Therefore, an open condenser C_2 causes *degeneration*, the opposite of regeneration; oscillation can never develop from this defect.

However, oscillation may occur if an open develops in a by-pass condenser that is used in more than one stage. For an example, see Fig. 4. Here the cathodes of both tubes use a common bias resistor R_1 , which is by-passed by C_3 . Should C_3 open, the plate current of VT_2 flowing through R_1 would develop a signal voltage across R_1 that would be *in phase* with the signal applied to the input of tube VT_1 . Therefore, when there is a circuit common to two or more tubes, an open cathode by-pass condenser may cause trouble that would not occur if the condenser were used across the bias resistor in a single stage.

As you have already learned, a defective screen grid by-pass condenser may cause oscillation. Thus, if C_4 in Fig. 4 opens, then both stages are likely to oscillate because their screen grids are no longer effective as shields between the plate and grid circuits.

Condenser C_5 is the r.f. by-pass for the B+ circuit of the two stages. If it opens, the r.f. components of the

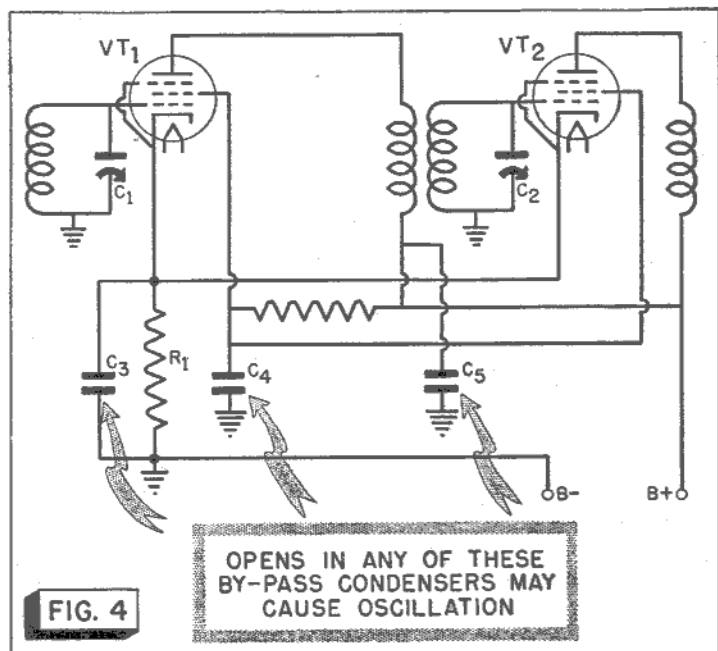

plate currents can get into the power supply leads and be coupled to other circuits in the right phase to cause oscillation. Although C_5 is in parallel with the output filter condenser, the filter condenser cannot assume the function of C_5 because electrolytics have higher power factors than do paper condensers, and also they are inductively wound; both conditions make them poor r.f. by-passes.

Of course, you know that a *short circuit* in either condenser C_4 or C_5 will remove operating voltages and so kill the receiver. Therefore, you won't worry about shorts in these condensers when oscillation is the complaint.

In Figs. 3 and 4, we have shown standard r.f. stages, but i.f. stages could be substituted just as well by using i.f. transformers. The same conclusions hold in either case.

Audio Section Troubles. Now, let's look at the typical audio amplifier shown in Fig. 5. There are two condenser troubles that may cause oscillations in this circuit.

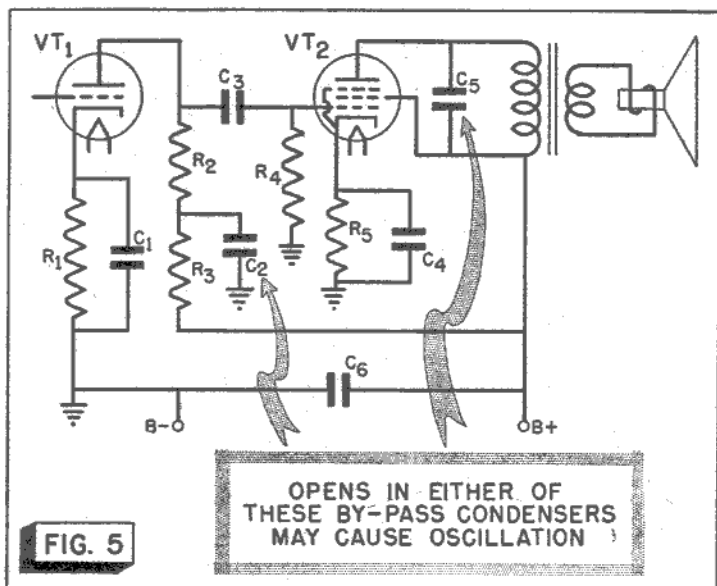

FIG. 5

If condenser C_6 opens, there is some possibility that oscillation will develop in the audio amplifier. This by-pass condenser prevents the power output tube from acting as an r.f. oscillator. It may seem impossible for this tube to be an r.f. oscillator, since there are apparently no circuits in the stage that are tuned to radio frequencies. However, you must remember that even a short piece of wire has inductance, and the transformer leakage inductance is added to this. In addition, there is capacity between wires, and distributed capacity in the transformer. Therefore, it is possible for the grid and the plate circuits in an output tube to have just the right inductance and capacity to form resonant circuits at some high radio frequency. Oscillation then may occur, because a power output tube has such high power sensitivity that it will provide considerable feedback at the slightest opportunity.

The by-pass condenser C_2 is frequently important in preventing oscillation. As you know, the plate current of the output tube VT_2 has a high audio frequency (a.c.) component. Since the a.c. plate circuit of this tube is completed by output filter condenser C_6 from B+ to ground (and through C_4 to the cathode), there will be

an a.c. voltage across C_6 that depends on the a.c. plate current and the condenser reactance. The high a.c. current of VT_2 causes considerable a.c. voltage to exist across C_6 , even when the condenser is in the best of condition, and there will be a greater drop if this condenser loses capacity or develops a high power factor. If this a.c. voltage is applied to the plate circuit of VT_1 , it will be fed through C_3 back into the grid circuit of VT_2 and will be in proper phase to support oscillation. Oscillations produced in this way will usually cause the "motorboating" noise we referred to earlier. Condenser C_2 and resistor R_3 are used both to prevent such motorboating and to help eliminate hum. The low reactance of C_2 causes most of the a.c. variation in the plate supply voltage to be dropped across R_3 , rather than to be applied to the signal circuits of VT_1 . An open in C_2 can, therefore, permit both motorboating and hum.

The filter condensers are another possible cause of oscillation that you should not overlook. In some of the less expensive receivers, the output filter condenser must act as a by-pass for all plate supplies—the B circuits of all the tubes are brought directly to this condenser with no intervening R-C filters.

As we have said, an electrolytic condenser is a rather poor r.f. by-pass condenser at best, and an even worse one when it develops a high power factor. It is easily possible for this condenser to become so ineffective as an r.f. (or a.f.) by-pass that it will permit coupling between stages.

When this condition is suspected, and the receiver hum is *not* abnormal, you will probably find that a small paper by-pass condenser (.05 to .1 mfd.) connected in parallel with the output filter condenser will clear up the trouble. (In fact, many receivers have such paper by-pass condensers.)

Of course, if the hum level is abnormal, the filter condenser must be replaced as well.

Shielding Troubles. We have mentioned that a lack of shielding may cause trouble. Let's investigate this problem a little more closely, because there are several possible conditions.

A quick glance over the receiver while looking for surface defects will show you whether tube shields are missing or not, because you can see where shielding bases or shielding clamps are installed on the chassis. Naturally, if you see a base or clamp with no shield over the corresponding tube, you know the shield is missing.

In addition, you should always check the original tube list to make sure a metal tube originally used in the receiver has not been replaced by a glass tube. Receivers that are designed specifically for metal tubes will have no provision for shields, because metal tubes are self-shielding. However, if some serviceman has replaced a metal tube in the i.f. or r.f. stages with a glass tube, it is possible for feedback to occur. There are two possible cures here—you can either install a metal tube, or shield the glass tube.

Sometimes, even when the shielding is present, a poor electrical contact between the shield and the chassis makes the shield ineffective. Always suspect this possibility if the shield base is held to the chassis by rivets, because corrosion at the rivets may destroy the electrical contacts between the shield and the chassis. (A good check for this condition is to ground the shield to the chassis with the blade of a screwdriver. This should not affect the operation of the receiver; if it does, the shield-chassis contact is poor.) If the shield base does not make good contact with the chassis, it is advisable to drill out the rivet and use a bolt, a nut, and a lock-washer. This applies to shields used over r.f. or i.f. transformers as well as to those used over tubes.

Where the shield makes contact to the chassis through a spring, be sure that the spring presses tightly against the shield and that there is no corrosion between the spring and the shield.

Incidentally, while we are considering poor contacts—sometimes a poor contact at the rotor shaft of the tuning condenser gang is responsible for oscillation. As you know, the only contacts between the rotor shaft and the chassis are made through the end bearings and through the spring wiping contacts. Actually, the wiping contacts are depended on for most of the electrical

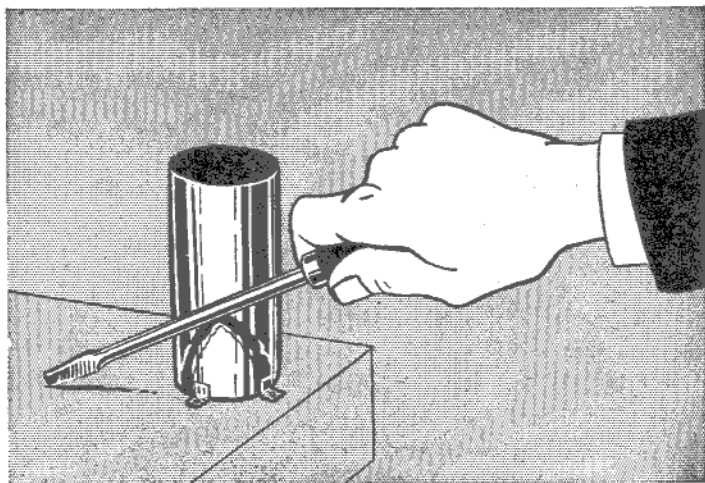

How to check for a poor contact between shield and chassis. If grounding the shield to the chassis with a screwdriver this way affects the operation of the set in any manner, the connection between the shield and the chassis is poor.

continuity. If one of these contacts weakens, or if dust or corrosion collects under it, it will not make good contact to the shaft of the condenser. As you learned in your Course, this will force the current that would normally flow through the contact to travel along the rotor shaft and flow through the other contacts instead. The linkage thus produced between the various tuned circuits may cause oscillation.

Circuit Wiring. One of the circuit stabilizing procedures of the receiver designer is to find the proper position for critical leads. This "lead dress" is frequently important—even a slight shift in lead position may increase feedback enough to cause oscillation. A serviceman may move one of these critical leads out of position when he replaces a part. Examine any oscillating receiver for evidence of previous repair. If it has been serviced before, check the manufacturer's service information; these often give instructions for proper lead positioning.

Alignment Troubles. Oscillation in a circuit may sometimes be the fault of improper alignment. We mentioned earlier that the Q of a resonant circuit has much

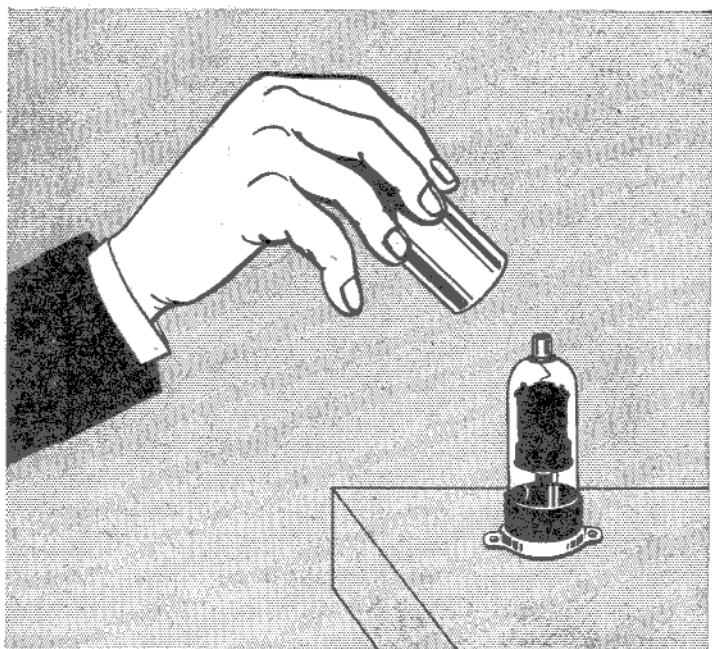

A missing shield is often the reason why a set goes into oscillation. Whenever you remove a shield from a tube, *be sure to replace it* before considering the repair finished. Do not depend on the operation of the set to tell you whether a shield is missing; it is entirely possible for a set to work properly for a while with a missing shield, only to go into oscillation later on because, say, the characteristic of some tube changes.

to do with the ability of a circuit to oscillate (the higher the Q , the greater the feedback voltage developed across the circuit when the feedback path is caused by stray capacitive coupling—see Fig. 2). This Q , in turn, depends upon the adjustment of the resonant circuits, and it is possible for there to be such a misalignment that the Q is affected. Also, the circuit may be adjusted so that the plate circuit is highly inductive, so that the feedback is in the right phase to cause oscillation if its path is through grid-plate capacity. In either case, re-aligning the receiver will frequently clear up the trouble. Since you have not yet studied alignment, this is something to remember for future reference.

Conditions Not Due to Receiver Defects. There are a number of conditions that are not receiver defects but

will cause squeals. For example, there may be radiation from the local oscillator of some nearby receiver. This condition is obvious because the whistle will either "pass through" the signal to which the receiver is tuned, or, if it happens to remain on that station frequency, it will interfere only with that one station until the radiating receiver is again retuned. On the other hand, practically any case of receiver oscillation will cause a whistle on most (or all) received signals.

It is always possible that there will be a squeal or oscillation at the frequency on the broadcast band dial that is twice the i.f. frequency of the set. Thus, if the i.f. frequency happens to be 455 kc., there may be a squeal if you try to tune to a station at 910 kc. Again the condition is an obvious one because it occurs at only this one frequency—not on all stations over the broadcast band.

There are several other conditions that may cause squeals when you tune to one or two stations, but do not cause squeals on all of them. For example, an excessively long antenna may feed in interfering station signals to such an extent that the preselector cannot cut them out. Also, when you tune to certain stations, harmonics of the receiver oscillator may beat with other stations to produce the i.f. frequency, and so may cause a squeal at some one or two points on the band.

► Remember—squeals caused in any of the ways just given cannot be eliminated by repairing the set, because the set is not defective. You can shorten an antenna if it is the cause of squeals, and the i.f. setting may be changed somewhat (when you learn about alignment) when the second harmonic interferes with a desired station signal. Otherwise, there is little you can do but explain the reason for the squealing to the customer.

LOCALIZING OSCILLATION

Oscillation is not always as easy to localize as are some of the other troubles, because more than one stage may be involved. That is, feedback may go from one stage to a preceding stage one or two positions back toward the antenna. Making tests in one of these stages may kill the oscillations temporarily, as you will learn

a little later on, but this does not necessarily mean that you have found the defective stage. It may be that a defect in the other stage is really the cause, so you may have to locate both stages to cure oscillation permanently.

► While you are confirming the complaint, determine whether oscillation can be heard at all times, whether or not a signal is tuned in. If it can, then the trouble is probably in the audio amplifier, although it may be in the i.f. stages. Turn the volume control on the receiver to the minimum volume position. If the oscillation is still audible, then it is definitely in the audio amplifier. However, if it disappears, either the feedback is through the volume control circuit, or the actual source of oscillation is in the i.f. stages of the receiver.

If the oscillation or squealing is audible only when stations are tuned in, but it occurs on *all* stations, the probable location of the difficulty is in the i.f. stages.

On the other hand, if the squeals are heard only when stations are tuned in, but they occur mostly at one end of the tuning band, the trouble is more likely to be in the r.f. or preselector stages of the receiver.

► If the trouble appears to be in the audio section, you should first check for defective filter or by-pass condensers, since these are the only common sources of difficulty in the audio section of the receiver. The best test is to try other condensers across those you suspect (with the receiver turned on) to determine if the squealing or motorboating will stop while the test condenser is in place. If so, and the receiver then plays normally, replace the condenser across which the test condenser is being held.

► If the trouble appears to be in the i.f. amplifier, check the screen-grid by-pass condenser and be sure the shielding is in place. However, if these obvious sources of oscillation are O.K., then it will be best to localize the trouble to a stage before making other tests.

Signal Tracing. A signal tracer can often be used to localize the stage that is oscillating. However, there is always a possibility that the tracer will stop the oscillation when the probe is brought near the section you wish

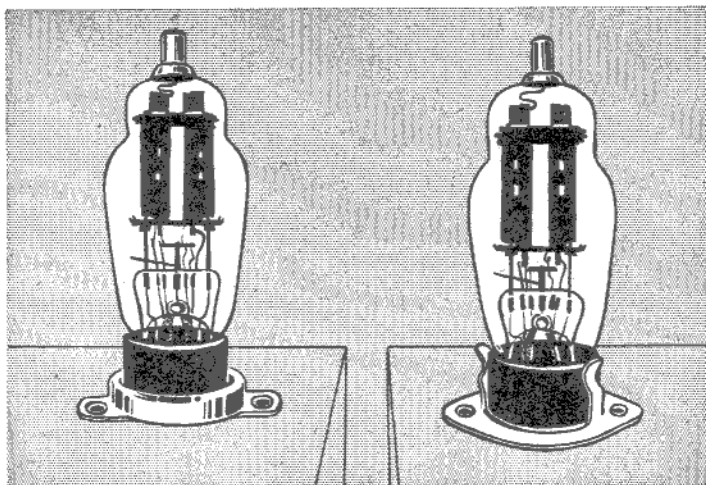

Look for indications of missing tube shields when you inspect a set that is oscillating. If a shield was used originally, the shield base, through which contact is made between the shield and the chassis, will still be in place around the tube socket. The illustration above shows two types of shield bases. Other kinds are also used.

to check, so do not expect the instrument to work in every single case.

The place to start with the signal tracer depends on where you have localized the oscillation. If the oscillation can be heard all the time, regardless of the position of the volume control, start your signal tracing at the first audio stage. On the other hand, if it can be heard all the time except when the volume control is turned down, start in the i.f. stages. Finally, if the oscillation is audible only when a signal is tuned in, start in the r.f. stages.

► When you are tracing in the i.f. or audio stages, tune the set to some point on the dial where you do not hear a station. Start tracing at the first grid in the section and move back through succeeding grid circuits toward the loudspeaker. When you first hear the oscillation from the signal tracer as well as from the receiver, your probe is touching a stage that is involved in the oscillation.

If you are tracing in the r.f. section, follow the same procedure with a signal tuned in. Work from the input of the receiver toward the loudspeaker, tracing at each control grid in turn.

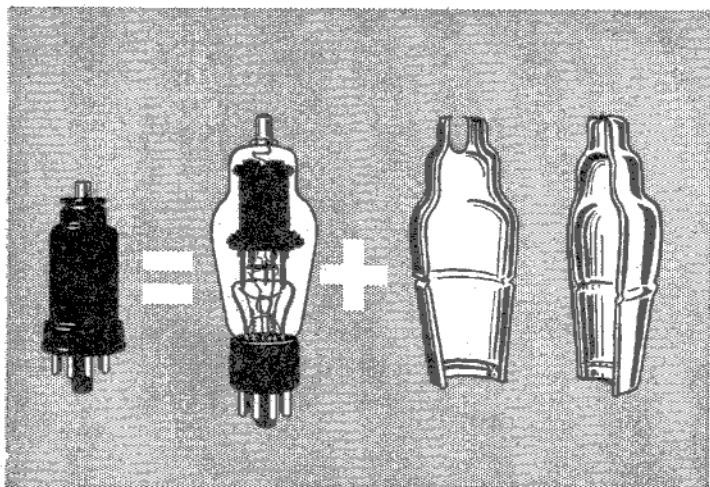

Remember that a metal tube is shielded by its own outer shell—in other words, a metal tube is equal to a glass tube plus a shield. Oscillation sometimes occurs because a serviceman replaces a metal tube with its glass equivalent and neglects to shield the latter. Always keep this possibility in mind when you service an oscillating set. The tube complement list in the manufacturer's service information will tell you which tubes should be metal. Often this list is also on a label pasted to the chassis or cabinet.

► When you do not have a signal tracer, you must rely on other methods. Of these, stage blocking and signal injection are best for localizing the defective stage.

Stage Blocking. If the squeal or motorboating is audible all the time, even when a station is not tuned in, the stage blocking method of locating the trouble can be used. The procedures are like those used in localizing hum. That is, you can pull out tubes one at a time, moving from the output back toward the input, if the set is an a.c. receiver or an auto set with the tube filaments connected in parallel. As an alternative procedure, you can hold a .1 to .5 mfd. by-pass condenser across the grid input in a stage-by-stage test procedure. (When the chassis is connected to B—, the condenser is held between grid and chassis; otherwise the B— or grid return circuit must be located, and the condenser must then be held between the grid and B—.)

► Let's suppose you have an a.c. receiver and can pull out the tubes. Start with the first audio tube. If the oscillation disappears when this tube is pulled out, the

trouble is either in this stage or in some stage nearer the input of the receiver. If it continues, however, the power output stage is oscillating.

If the oscillation stops when the first audio tube is out of its socket, re-insert this tube, and pull out the second detector if it is a separate tube. If the second detector is in the same tube envelope as the first audio tube, then pull out the last i.f. tube instead. Continue moving in this manner back toward the input until you find a tube that can be pulled out without killing the oscillation. The stage next toward the loudspeaker is then the one in which the oscillation is occurring.

► The by-pass condenser method of stage blocking can be used in almost exactly the same manner and will work on a.c.-d.c. and battery receivers as well as on standard a.c. sets. Try the condenser first from the grid of the power tube to the chassis (or to B— if the chassis is not connected to B—). This should kill the oscillation unless it is occurring in the power stage.

If it does kill the oscillation, then move back to the grid circuit of the first audio tube, and again try your condenser across the grid input. If this kills the oscillation, connect the condenser across the load of the second detector. If the oscillation is killed, use your condenser across the grid input of the i.f. tube. By moving back in this manner, you will eventually reach a grid circuit where the oscillation is *not* affected. When you do, the stage next toward the loudspeaker is again the guilty one.

Remember at all times, however, that more than one stage may be involved. If you can find no defect in the stage you believe to be at fault, or if repairing whatever defect you do find does not put an end to the oscillation, make a careful check for defects in each of the other stages between the suspected stage and the loudspeaker. Start with the stage next to the suspected one. Incorrect placement of leads, stray magnetic coupling, or a defect in a by-pass condenser used in both stages are the most common causes of this inter-action between stages.

Signal Injection. If the oscillation can be heard only when a signal is tuned in, it may be possible to use a

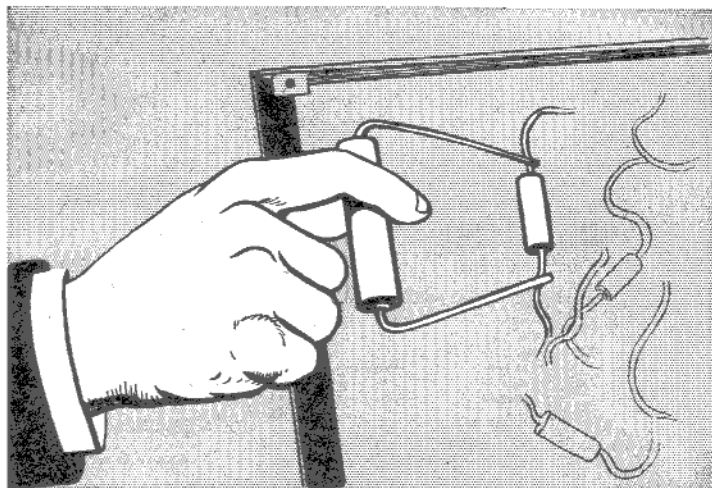

When you connect a test condenser across one already in a circuit, hold it with your thumb and forefinger like this. Never grasp the test condenser with your whole hand while making tests; you may introduce stray voltages, provide a leakage path, or even get a shock.

signal generator to localize the defective stage. To do this, tune your s.g. to the same frequency as that to which the receiver is tuned, and connect the s.g. to the input terminals of the set. Connect the s.g. ground lead to the chassis, and the "hot" lead to the antenna post. You should now hear the squeal along with the signal generator modulation tone. If you wish, you can use the signal generator unmodulated and allow just the r.f. signal to come through; in this case, you will hear only the squeal.

When you are sure that you are hearing the oscillation, move the s.g. back toward the output. In other words, move the hot lead from the antenna terminal to the grid circuit of the first detector. If you still hear the squeal, change the signal generator setting to the i.f. frequency, and move the hot lead to the grid of the first i.f. tube. Continue in this manner to the input of the second detector. There is no need to check in the audio section, because you know from the fact that the squeal occurs only when a signal is tuned in that the defect must be in the r.f.-i.f. section.

This test shows you the opposite of what the blocking

test reveals. When you connect the generator and fail to hear the oscillation, the trouble is in the next stage *back* toward the antenna or *in the stage to which the signal generator is connected*. The latter is a possibility because the signal generator detunes and loads the circuits across which it is connected, so it can actually kill oscillation when it is connected to the defective stage.

► Once you have found the defective stage, shunt its by-pass condensers with others to see if a condenser is open, and check the operating voltages. Also, check the shielding to see that it is in place, and check its grounding by touching it and the chassis firmly with a screwdriver blade. Examine the circuit for evidence that someone has tampered with the wiring. If you do not have any instructions for lead positioning, try moving the grid and the plate leads in the oscillating stage with an insulated probe or pencil. Have a signal tuned in, and watch for a change in pitch of the squeal. If a change in pitch occurs, try to find a wire position that will cure the

Two major requirements for becoming a professional serviceman are good training and determination to get ahead. Given these, even a serious physical handicap is no bar to success. This graduate is an inspiring example. Although he is confined to a wheel chair, NRI training and his own will-to-win have allowed him to build a very successful radio servicing and merchandising business for himself.

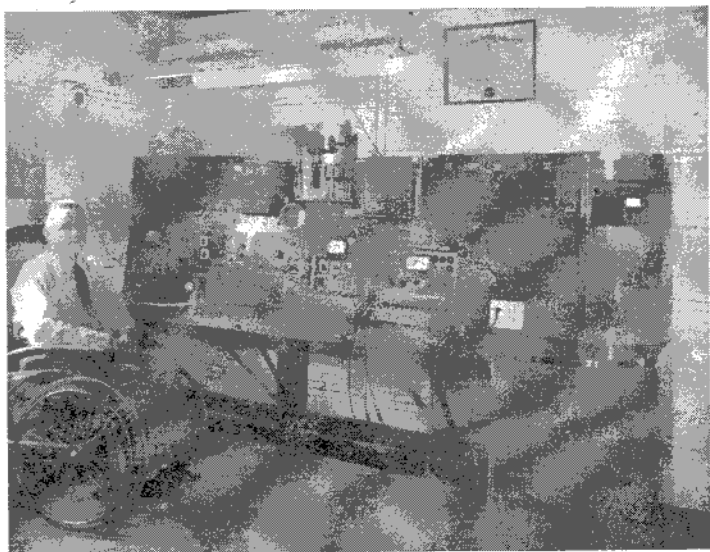

oscillation. In general, grid and plate leads should be kept short and should be separated as much as possible.

If the trouble persists, try another tube and realign the circuit. (A later Booklet will show you how.)

NRI PRACTICAL TRAINING PLAN

Introducing oscillations into the receiver you are using for practical training may or may not be easy. Many radio receivers are so stable that you can change the bias or remove shielding without causing oscillation.

Of course, disconnecting a screen-grid by-pass condenser will almost invariably cause the trouble. Also, deliberately increasing the length of the grid and the plate leads in an r.f. or i.f. stage will usually produce squeals.

You can try these, one at a time, to introduce oscillation and to get practice in isolating this defect. Then, try creating the other conditions described in this Booklet. However, don't upset the alignment in your efforts to introduce oscillation; wait until you have learned to align receivers before taking this step.

THE N. R. I. COURSE PREPARES YOU TO BECOME A
RADIOTRICIAN & TELETRICIAN
(REGISTERED U.S. PATENT OFFICE) (REGISTERED U.S. PATENT OFFICE)

COMMON CAUSES OF OSCILLATION

These causes of oscillation are listed according to the symptoms they produce, with the most common first.

1. *Oscillation audible whether or not a station is tuned in and regardless of position of volume control.*

The defect is in the audio stages. Possibilities: open filter or by-pass condensers.

2. *Oscillation audible whether or not a station is tuned in, but affected by position of volume control.*

The defect may be in the i.f. stages, in the second detector, or in the first a.f. amplifier. Possibilities: open filter or by-pass condensers; shielding missing or making poor contact; alignment off; excessive screen grid voltage; leads improperly placed.

3. *Oscillation audible only when station is tuned in, occurs on all stations.*

The defect probably is in the i.f. stages, but may be in the r.f. Possibilities: open by-pass condensers; shielding missing or making poor contact; alignment off; excessive screen grid voltage; low bias; leads improperly placed.

4. *Oscillation audible only when station is tuned in, occurs primarily at one end of tuning band.*

The defect is in the r.f. stages. Possibilities: open by-pass condensers; shielding missing or making poor contact; poor contact at tuning condenser rotor shaft; excessive screen grid voltage; low bias; alignment off; leads improperly placed.